

THE INFORMATION CONTAINED IN THIS DRAWING IS THE SOLE PROPERTY OF MUSCLE MACHINE AB. ANY REPRODUCTION IN PART OR AS A WHOLE WITHOUT THE WRITTEN PERMISSION OF MUSCLE MACHINE AB IS PROHIBITED.

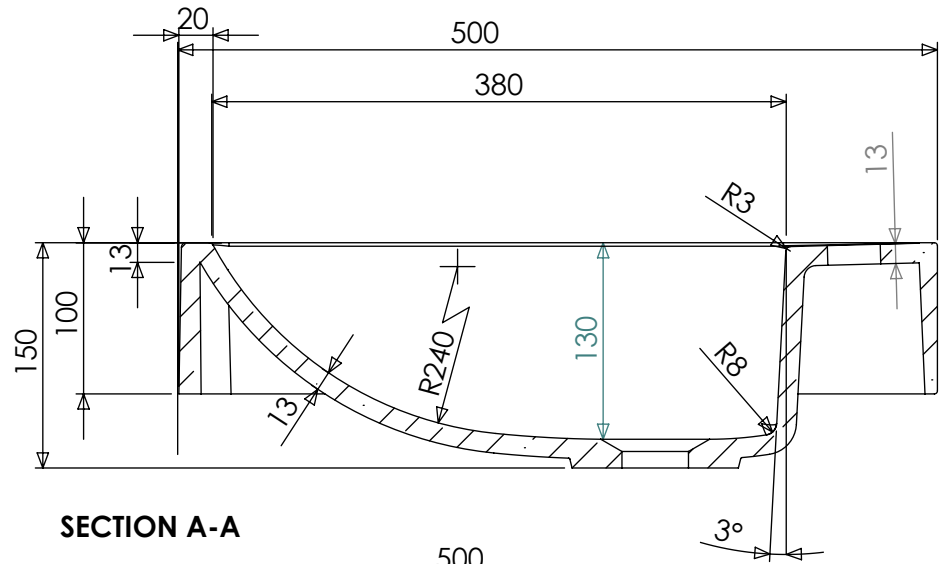

SECTION A-A

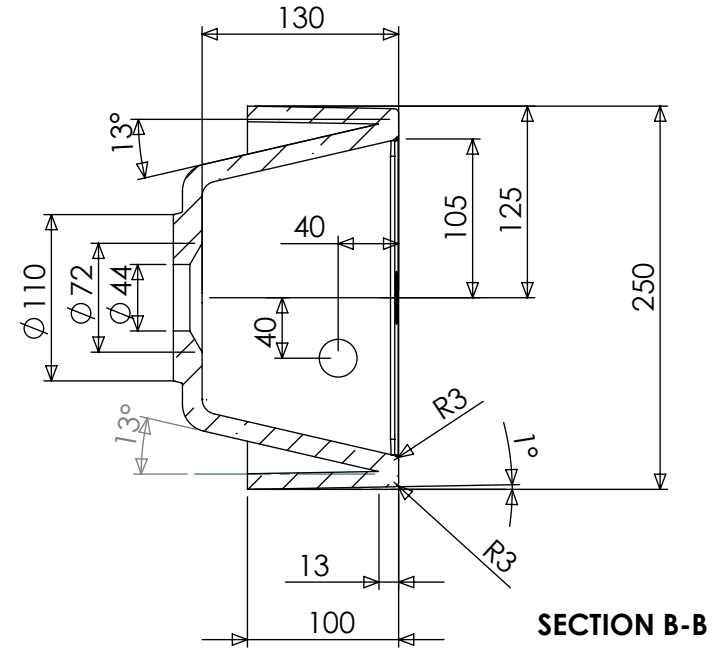
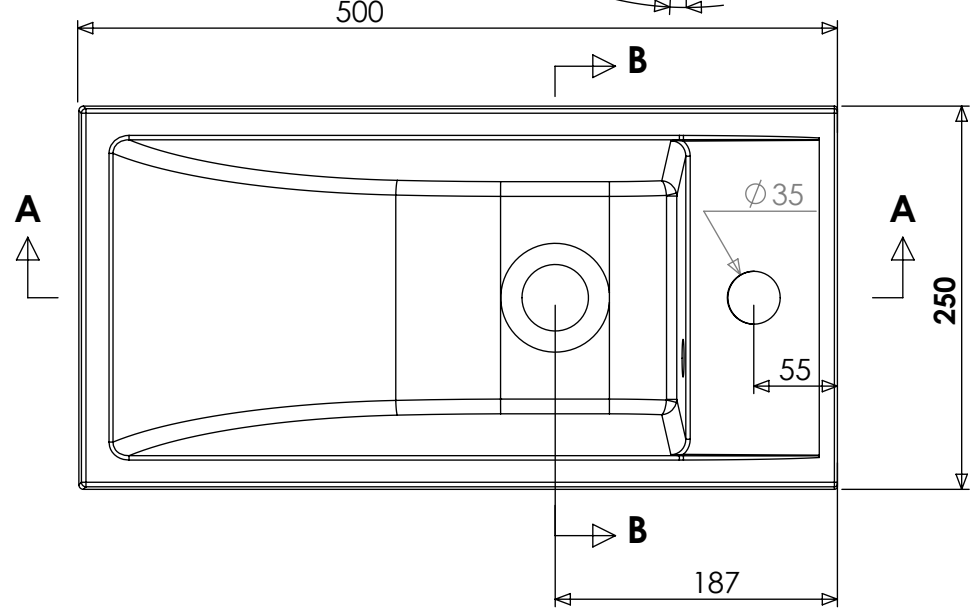
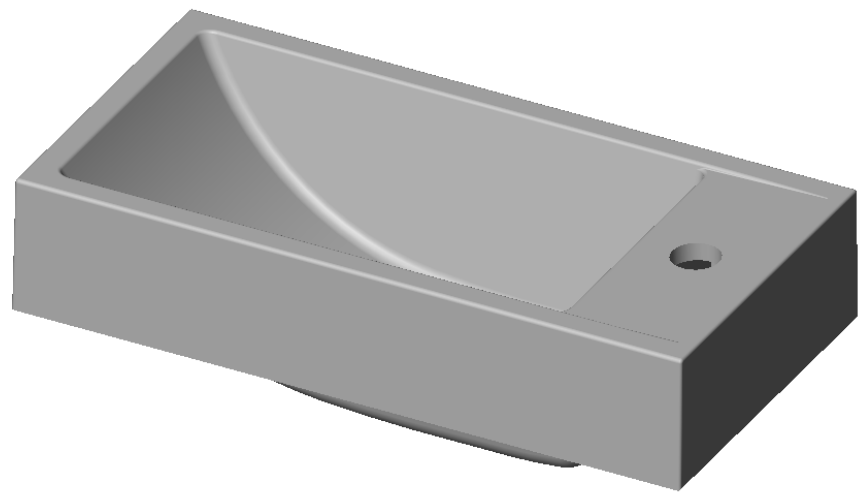

SECTION B-B

Tolerance length	+3/-0 mm	DALLE	DR	041207	SCALE-1:5	MARMITE	500c
Tolerance length granite	+1,5/-1,5 mm	Muscle Machine AB		MARTINA 500 c			
Tolerance taphole location	+3/-3 mm	marmite [®]		1046051xx			1:8
Variation overflowhole location	+3/-3 mm						
Tolerance plane bending	+1,5/-1,5 mm						